



EXHIBITOR RESOURCE GUIDE

- SHOW DATES & HOURS
- MOVE-IN & MOVE-OUT SCHEDULES
- BOOTH SET-UP INFORMATION
- INSURANCE REQUIREMENTS
- EXHIBITOR RULES & REGULATIONS

Renfro Productions & Management, Inc. would like to thank you for being a part of the **36th Annual Indianapolis Fall Boat & RV Show**. Please thoroughly read this Exhibitor Guide; it will save you time, money, and help make the event a success for you.

TABLE OF CONTENTS	PAGE
Show Management Contact Information.....	2
Event Contractor Information	2
Event Location & Show Schedule.....	2
Exhibitor Check-in & Move-in.....	3
Exhibitor Move-Out & Tear-down	3
Booth Construction – Instructions w/diagram	3-4
Insurance Information & Requirements	4-5
Show Decorator Information	5
Forklift Availability.....	5
Signage.....	5
Cleaning of Exhibit Space.....	5
Electricity.....	6
Internet/Telephone	6
Staffing Exhibit	6
Exhibitor Credentials.....	6
Exhibitor Parking	6
Truck & Trailer Parking	7
Event Security	7
Free Drawings, Give-aways, Raffles, etc.	7
Indiana State Fire Marshal Regulations	7-8
Pets/Animals	8
Indiana State Fairgrounds Map	9

SHOW MANAGEMENT CONTACT INFORMATION

Show Website: <https://indyfallboatandrvshow.com/>

Email: info@renfroproductions.com

Contact	Position	Phone
Kevin Renfro	Show Director	(765) 400-5002
Mark Kaley	Operations Director	(765) 400-5003
Mitch Renfro	Operations & Sales	(765) 400-5004
Todd Jameson	Marketing Director	(765) 400-5007
Elaine Johnson	Exhibitor Services	(765) 400-5000
Candice Geyer	Exhibitor Services	(765) 400-5005

EVENT CONTRACTOR INFORMATION

Contractor	Contact	Phone	Email
Fern Exposition & Event Services ~ Show Decorator			
	Randy Fisher	(317) 803-3779	rfisher@fernexpo.com
Indiana State Fairgrounds ~ Internet / Wi-Fi / Telephone			
	Requests, Questions, Orders	(317) 927-7500	events@indianastatefair.com
ERMCO ~ Electric	Eric Edwards	(317) 423-3766	eedwards@ermco.com
➤ Electrician	Jake VanWye	(317) 416-7158	jvanwye@ermco.com
➤ IT	Paul Gaddie	(317) 517-0853	pgaddie@ermco.com

EVENT LOCATION:

Indiana State Fairgrounds
Fall Creek Pavilion
1202 E 38th Street
Indianapolis, IN 46205
Switchboard: (317) 927-7500
Fairgrounds Security: (317) 927-7520

EVENT SCHEDULE:

Friday, September 19th10:00am – 8:00pm
Saturday, September 20th10:00am – 8:00pm
Sunday, September 21st10:00am – 5:00pm

EXHIBITOR CHECK-IN

Check-in starts on Wednesday, September 17th at 8:00am. The check-in office is located at the main (north) entrance of the Fall Creek Pavilion and is open from 8:00am to 6:00pm.

Any balance due on your booth space must be paid before you move-in or set-up.

MOVE-IN SCHEDULE

Bulk Space	Wednesday, September 17 th	8:00 am – 8:00 pm
Bulk Space	Thursday, September 18 th	8:00 am – 8:00 pm

Booth Space	Thursday, September 18 th	12:00 pm – 8:00 pm
Booth Space	Friday, September 19 th	8:00 am – 9:30 am

TEAR DOWN / MOVE-OUT SCHEDULE

Sunday, September 21 st	5:01 pm – 9:00 pm
Monday, September 22 nd	7:00 am – 9:00 am

In accordance with the Rules and Regulations of your lease agreement, no exhibit or display is to be dismantled before official close on Sunday, September 21st. **We insist that nobody start tearing down until we have announced over the PA system that the show is officially closed.** We cannot allow you to carry or move anything out of the building before said announcement. Any exhibitor found starting to tear-down before 5:00pm will automatically be removed from our mailing list. **Everything must be moved out of the building by 9:00am, Monday, September 22nd. Units can be staged outside of the building.**

BOOTH CONSTRUCTION INFORMATION

The following information is intended to allow equal exposure by all exhibits. The purpose of exhibiting is to sell. These rules are for your benefit and will be strictly enforced.

The show has made every effort to provide a quality buying environment for our guests. Signs, clothing or items with offensive wording or displays will not be allowed. We hope you will want to be invited back next year. Please make every effort to have a quality appearing exhibit.

- **Any exhibitor using steps or platforms in the booth must have hand rails installed on them by show opening Friday, September 20th at 10:00 am. This is a safety rule that must be complied with. Nobody will be allowed to open without them.**
- **Booth displays & signs are limited to 8' and shall not project more than 4' from the background. Decorations shall not obstruct adjacent exhibits nor project into aisles.**
- **Balloons, stickers, and handmade signs are strictly forbidden.**
- **24-hour security is in effect. We suggest you cover all merchandise at the close of each evening and rope off your display.**

- The following diagram below clearly indicates the guidelines required for linear booth participation in our show. All exhibit fixtures should be contained within the grey outlined areas shown.

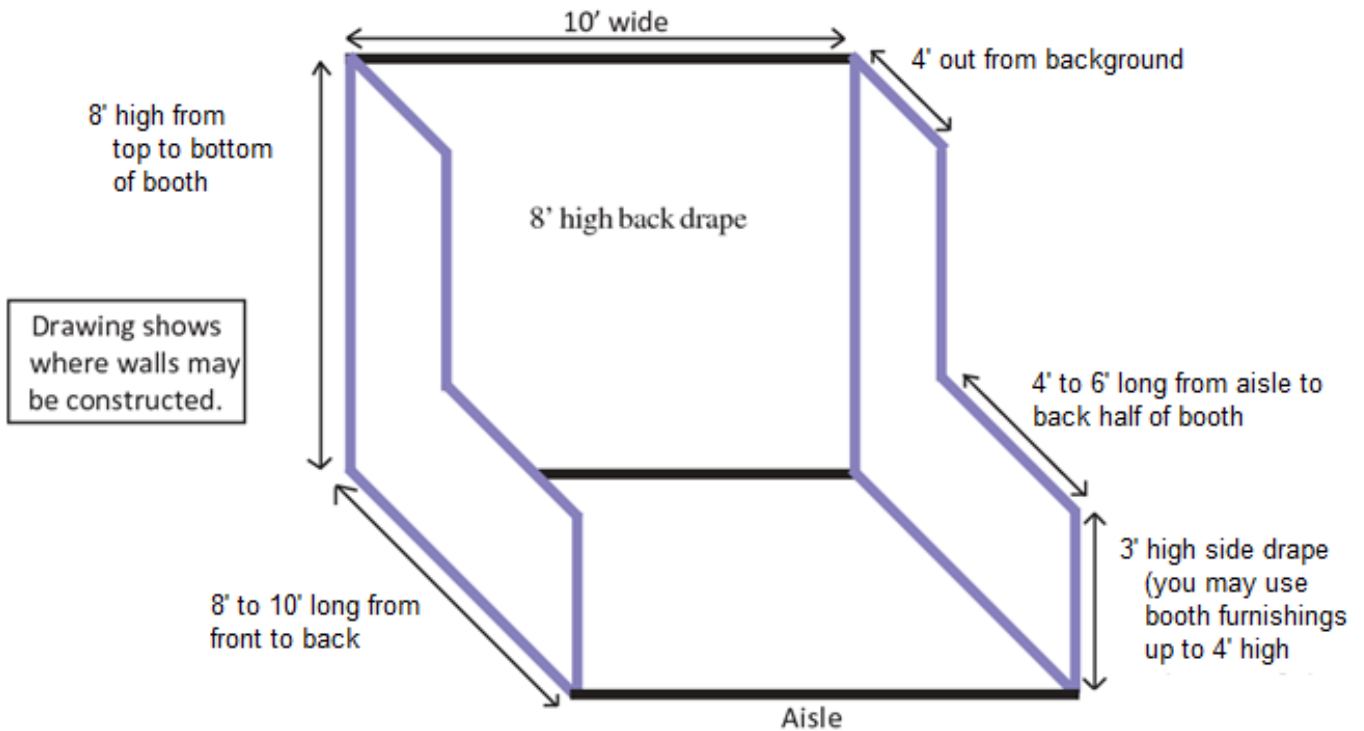

BOAT & RV DEALERS

Forklifts may be contracted with the **Show Decorator** (Fern Exposition & Event Services). Contact them for hourly rate and to schedule forklift use. Clean-up crews will be allowed into the building 3 hours before show time each day; they should report to the **West Pavilion Exhibitor Entrance**.

Special note to dealers hanging signs from the rafters: Signs must be hung from I-beams only; **DO NOT** hang anything from gas or electrical conduit.

INSURANCE INFORMATION & REQUIREMENTS

The insurance requirements are designed to protect your company and Renfro Productions' managed events. The following questions will be answered in this section regarding insurance for participation in the Indianapolis Fall Boat & RV Show.

ALL EXHIBITORS must provide Show Management with a **Certificate of Liability Insurance** in the amount required by the Indiana State Fairgrounds (\$2,000,000 General Aggregate with 1,000,000 Per Occurrence).

A Certificate of Liability Insurance with "additional named insured" endorsements furnish coverage to the "additional insured" for liability "arising out of" the named insured's work, operations, or premises (or some variation on that theme).

When providing a Certificate of Liability Insurance with Additional Named Insured, the wording on the document is very specific and important; just as important as making sure the coverage amounts are accurate.

The descriptor section of the Certificate should read EXACTLY as follows:

Renfro Productions & Management Inc. and Renfro Expositions Inc. are named as “ADDITIONAL INSURED”.

Certificate Holder section should read as follows:

Renfro Productions & Management Inc.
Renfro Expositions, Inc.
6405 Dr. Martin Luther King Jr. Blvd.
Anderson, IN 46013

Make sure the dates of the policy cover the ENTIRE show period, including setup/teardown dates.

QUESTIONS SHOULD BE DIRECTED TO YOUR RENFRO PRODUCTIONS REPRESENTATIVE

If we are not provided with a Certificate of Liability Insurance you may not be able to exhibit. Should damage occur to the building or its property that is attributable to you (Exhibitor) or your (Exhibitor’s) staff, then it is your (Exhibitor’s) responsibility to reimburse the Indiana State Fairgrounds.

Please contact us if you have any questions regarding this requirement. Certificates of Liability Insurance can be emailed or faxed directly to our office at (765) 641-7756.

SHOW DECORATOR ~ FERN EXPOSITION & EVENT SERVICES

The **Show Decorator** will be onsite during the move-in hours of the show.

Fern Exposition & Event Services
1147 South White River Pkwy East Drive
Indianapolis, IN 46225
Phone: (317) 635-9606 • Fax: (317) 634-0993 • Email: indianapolis@fernexpo.com

FORKLIFT AVAILABILITY

Forklifts must be contracted directly with the **SHOW DECORATOR** (Fern Exposition & Event Services).

SIGNAGE

The **SHOW DECORATOR** (Fern Exposition & Event Services) provides a booth identification sign. If you require different signage, contact them directly.

CLEANING OF EXHIBIT SPACE

Debris from your booth must be swept or placed in the aisles after closing each evening. We cannot clean inside your booth. You may have janitor service at your own expense and contracted with the Show Decorator.

If you want to clean or straighten up your booth area, then you may come into the building, with proper credentials one (1) hour before show time. You will only be allowed into your own booth.

ELECTRICITY

Show Management furnishes one (1) 500 watt outlet per 10' of booth space. Bulk space exhibitors can use outlets on poles for cash registers, computers, TVs, etc. **Electricity for all spot lights, 500 watts and over, must be contracted with ERMCO and fees paid to them.**

If you require additional electricity – outside of what is provided – arrangements must be made directly with ERMCO at (317) 423-3766. ERMCO's price list/order form is posted on our website at:

<https://renfroproductions.com/wp-content/uploads/IFBRV2025-ErmcoElectricOrderForm.pdf>

INTERNET / TELEPHONE

If you require Internet (WiFi) access or a phone line in your booth, you must make arrangements directly with the Indiana State Fairgrounds. The main switchboard number is (317) 975-7500 and their price list/order form is posted on our website at:

<http://renfroproductions.com/wp-content/uploads/2025IFBRVS-IT-TechnologyOrderForm.pdf>

STAFFING OF EXHIBIT

Every exhibitor is responsible for having their exhibit area staffed at all times. The Show Management **INSISTS** that all exhibits be staffed during all hours open to the public.

EXHIBITOR CREDENTIALS

All Exhibitor Credentials are to be picked up at check-in. Exhibitor Pass Gates will be open one (1) hour prior to show time and your Exhibitor Credential must be presented to enter. Exhibitor Credentials are distributed as follows:

- **Booth Space:** Exhibitors with an 8'x10' or 10'x10' booth space will receive six (6) Credentials; one (1) additional Credential for each additional 8'x10' or 10'x10' booth space thereafter.
- **Bulk Space:** Exhibitors with 400 sq ft will receive six (6) Credentials; one (1) additional Credential for every additional 600 sq ft thereafter.

Additional Exhibitor Credentials may be purchased in advance as well as during the show for \$5.00 each. Exhibitors/Staff arriving without their Credentials may purchase a replacement Credential (with proper business ID) for \$5.00 in order to obtain entrance.

EXHIBITOR PARKING

Space is limited; we will distribute Parking Passes (provided by the Indiana State Fairgrounds) to best accommodate everyone. Exhibitor parking is **free** so long as you have a Parking Pass displayed on the dashboard or hanging from the rearview mirror of your vehicle.

BOX TRUCK & TRAILER PARKING

The Indiana State Fairgrounds requires all EMPTY box trucks and EMPTY (boat & cargo) trailers to be parked on the north side of the Fairgrounds, north of the race track (see the **blue highlighted** areas marked on the Fairgrounds map on page 9 of this manual).

PLEASE NOTE: No parking of ANY VEHICLES will be allowed close to occupied buildings. Contact the Fairgrounds Director of Parking, Gates & Security at (317) 927-7681, with any questions or concerns.

EVENT SECURITY

Security service is provided 24-hours daily through the course of the show including set-up and tear-down. Security will be posted throughout the entire show. Although we take every precaution to protect your property, we cannot be responsible for the disappearance of any item, especially if your booth area is left unattended. We suggest that you cover your booth and tables, and rope it off each evening.

FREE DRAWINGS/GIVE-AWAYS

Must be authorized by Show Management prior to the opening day of the Show! Contact Kevin Renfro at (765) 641-7712. Exhibitor must provide Show Management with a copy of product liability insurance covering any handout, free drawing and/or give-away requiring product liability insurance. Winning names and/or items must be left in the office before you tear down.

SHIPPING/MAILING ADDRESS

Address of the event facility is as follows:

Indiana State Fairgrounds
Fall Creek Pavilion & Exhibit Booth #
c/o [Exhibit Name]
1202 East 38th Street
Indianapolis, IN 46205

If you are having any packages shipped to the Fairgrounds, please have all shipments marked with the appropriate BUILDING and BOOTH NUMBER (e.g., West Pavilion #100).

INDIANA STATE FIRE MARSHAL REGULATIONS

This is a **No Smoking** facility; smoking will only be allowed in designated areas. Smoking IS NOT PERMITTED within the buildings.

- The Indiana State Fire Regulations & City Ordinances prohibits **ANYTHING** from protruding into the aisles. These rules will be strictly enforced.
- With regard to motorized vehicles, watercrafts and forklifts:
 - The maximum amount of gasoline permitted to remain in the tank is less than one-fourth ($\frac{1}{4}$) of a tank.

- Gasoline tank caps must be locked, taped, or sealed and approved by the State of Indiana Fire Marshal.
- All battery connections must be removed from the battery upon termination of the move-in until commencement of the move-out. Both positive and negative cable ends must be taped to avoid any chance of sparks.
- All Liquid Propane (LP) gas tanks must be removed from trailers, mobile homes and any other vehicles using LP.

PETS/ANIMALS

Exhibitors are not permitted to bring pets or live animals into the Show without prior permission from Show Management; with the exception of service and/or guide dogs.

